

Project:

Fixture Type:

Location:

Contact/Phone:

The LRKT544 is 5 inch LED Retrofit kit with Square Smooth. It is compatible with most of 5 inch standard recessed new construction and remodel housings. The retrofit kit comes with a E26 medium screw-base Edison adaptor for easy installation into standard incandescent sockets.

## DESCRIPTION

- Diecast construction provides lasting durability
- 4 different colors for trim White, Black, Bronze, Satin Nickel
- Torsion spring mounting style are designed to accommodate most 5 inch standard and shallow housings
- E26 medium screw-base Edison adaptor provides easy installation into Incandescent housings (GU10 and GU24 socket adaptor available - sold separately)

## LED LIGHT ENGINE

- Protected LED driver performs at 120V
- Dimming down to 10% with most dimmers
- CCT 2700K, 3000K, 4000K, 5000K available
- CRI ≥80 or ≥90
- Long life LED chips guaranteed up to 50,000 hours

## WARRANTY

Guaranteed five years from the purchase date of the product, against mechanical defects in manufacturing.

## LISTINGS

- cULus classified
- Energy star qualified
- Wet locations (Not suitable for coastal/salt water area)
- Damp locations
- RoHS compliances
- Tested in accordance with IESNA LM79 & LM80

## PERFORMANCE DATA

Input Voltage	120V
Input Power	16W
Frequency	50 / 60Hz
C R I	90
T Ambient	-30 °C ~40 °C (-22 °F ~104 °F)
C C T	3000 K
Lumens	950 lm

(all values at 25°C without a dimming control in circuit)

## LRKT544

5" LED Square Smooth Retrofit Kit

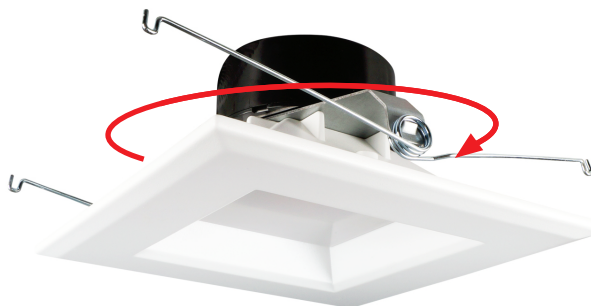

## DIMENSIONS

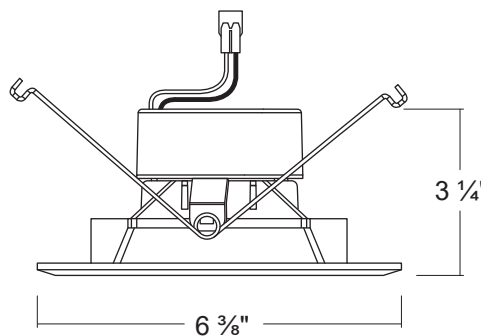

## PRODUCT CODES

Model NO.	Description
LRKT544W	5" LED Retrofit / Square Smooth / White
LRKT544B	5" LED Retrofit / Square Smooth / Black
LRKT544SN	5" LED Retrofit / Square Smooth / Satin Nickel
LRKT544BZ	5" LED Retrofit / Square Smooth / Bronze

### List of Triac Dimmer Switch

Mfr	Model #	Dimming Rate
COOPER	DLC03P	10 - 100%
Leviton	1A1505 / 1C1605	10 - 100%
Leviton	6631 / 6633	10 - 100%
Lutron	CT-603PG / CT-600PR	10 - 100%
Lutron	DV-600PR / DV603PG	10 - 100%
Lutron	DVW-603PGH / DVCL-153P	10 - 100%
Lutron	MACL-153M / TGCL-153P	10 - 100%
Lutron	S-600PR / S-2-LH	10 - 100%